

REVISIONS				
ZONE	REV.	DESCRIPTION	DATE	APPROVED
C6, D6	-	New dents and earth mark removed	2018-08-08	svma
	B	E-number added	2019-07-12	joan

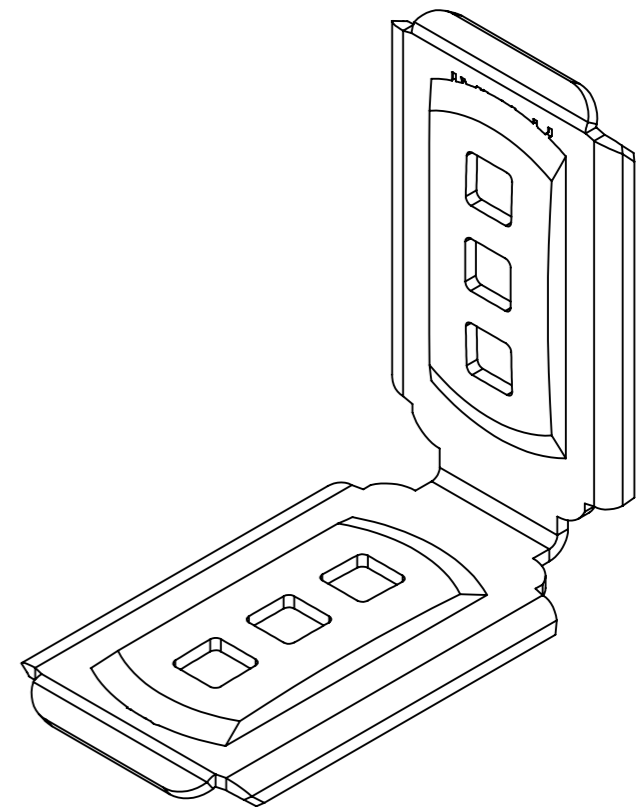

Article number	E-number	Type
2103	1133213	Zink plated DIN 50961
2203	1133265	Zinc-Nickel DIN 50979
2303	1133319	Acid proof AISI 316L
2703	1133383	Black Zinc Fe/Zn8/P4

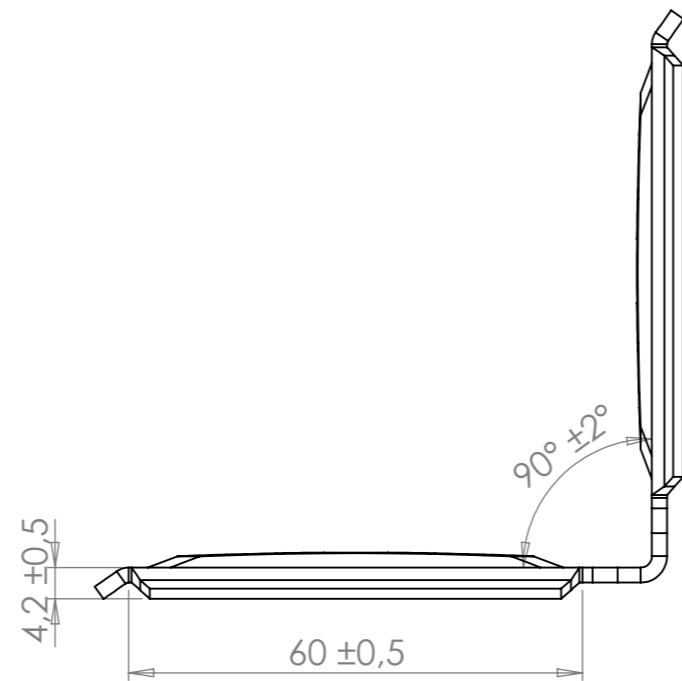
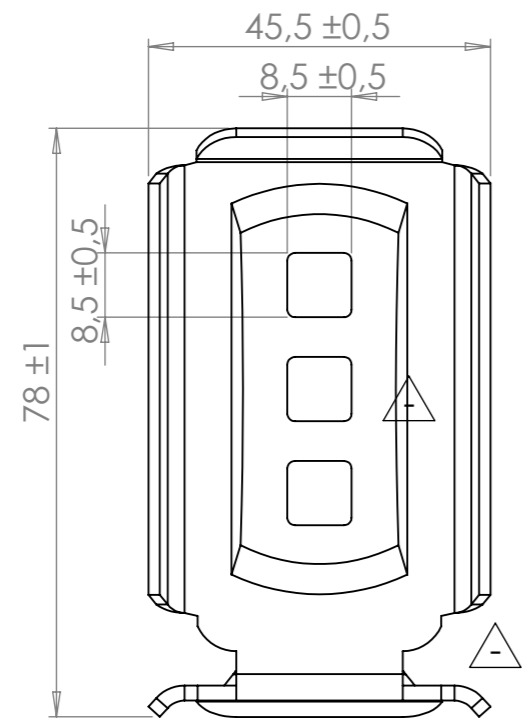

C-number C-0005261-01	Material
Description X3 Angled Fitting	Part / Assembly-ID Default(A-0003573)
Unless otherwise specified: SS-ISO 2768-1 MEDIUM	Rev. Sheet Name A.3 Sheet1
	Rev. Sheet B.1 A3
	Scale 1:1
	Weight (calculated) 92g

Finish / Color	Created By svma
	Created 2011-12-21
	Changed 2019-07-12
	joan

